

WINGSLAND S6

S6 User Manual V1.0

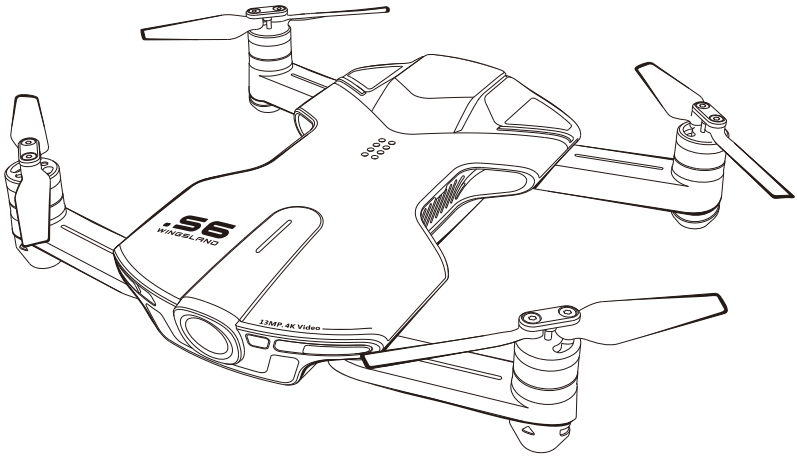

WINGSLAND

Height Changes Your Sight

Contents

Introduction	1
1.S6 Overview	2-5
1.1 Overview	2
1.2 What' s in the Box	2
1.3 Aircraft Diagram	3
1.4 Preparing the Aircraft	4
2.Flight Control	6-9
2.1 Flight Modes	6
2.2 Return-to-Home (RTH)	8
2.3 Flight Failsafe	9
3.WINGSLAND APP	10-14
3.1 Flying Interface Introduction	10
Intelligent Features	11
Accessories	11
3.2 Simulator	14
3.3 Editing	14
4.Flight	15-17
4.1 Fly Safe	15
4.2 Preflight Checklist	15
4.3 Operation	15
Appendix	18
Specifications	18
Certificate	18

Introduction

Thank you for purchasing the new intelligent drone S6, from Shenzhen Wingsland Technology Co., Ltd. For a stable and smooth flight experience. We recommend that read the Quick Start Guide and the User Manual before using this product. Train your operating skill by the inbuilt Flight Simulator in the WINGSLAND APP, make sure control the aircraft with a skilled operation.

If you have any questions about this product, please contact WINGSLAND technical support or WINGSLAND authorized dealer by sending a message or giving a call.

For user manual renewal, firmware upgrade, company announcement and more information, please keep up with the WINGSLAND official website: wingslandtech.com

Technical Support: service@szsungreen.com

Legends



Tips



Note



Warning

Video Tutorials

Please watch the tutorial videos at the link below.

Download WINGSLAND FLY APP

Download and install the WINGSLAND APP from App Store, Google Play, WINGSLAND official website or scan the QR code before using the aircraft.



APP Android



APP iOS



WINGSLAND FLY APP supports iOS 9.0 (or later) or Android 5.0.1(or later). Recommended Devices: iPhone, Huawei, Xiaomi, Lenovo, OPPO.

1.S6 Overview

1.1 Overview

S6 pocket drone, only weight 250g with the folding arms design, is a new generation recreational aircraft which is independent developed by WINGSLAND Technology. The camera features electronic image stabilization system, which can capture 13MP image and shoot ultra high definition video up to 4K at 30 frames per second or 1920*1080 at 60 frames per second.





With multi intelligent sense-components, optical flow sensor, ultrasonic module, built-in Dual satellite navigation and WINGSLAND advanced flight control system, S6 will always be your most reliable flying companion, to brings you a solid and remarkable flight experience whether indoor or outdoor.

S6 is also a modular flying platform for various accessories: boom gun, searchlight, and display board. Accessories will seamlessly attach to the upper shell of your S6 through extended port to boost the fun.

1.2 In The Box

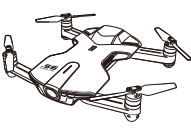
Check that all of the following items have been included in package before use.

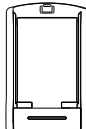
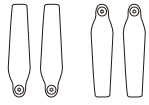
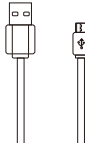
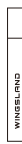
• S6 package list:

			
Aircraft x1	Portable box x 1	Battery x 1	Charger x 1
			
Propeller(4 pairs)	USB cable x 1	Screwdriver x 1	Documents x 1

1.3 Aircraft Diagram

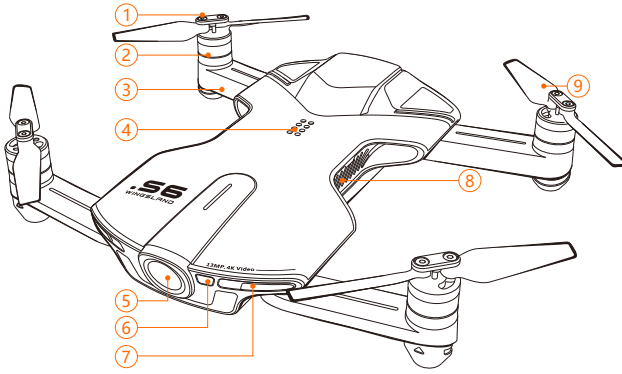

- ① Propeller Lock Screw
- ② Motors
- ③ Arm
- ④ Extended port
- ⑤ Built-in Camera
- ⑥ Flashlight
- ⑦ Front LEDs indicator(Green)
- ⑧ Ventilation Slot
- ⑨ Propellers

- ⑩ Footpads
- ⑪ Optical flow sensor
- ⑫ Ultrasonic module
- ⑬ Rear LEDs(orange)
- ⑭ Battery
- ⑮ Battery lock catch
- ⑯ Power button

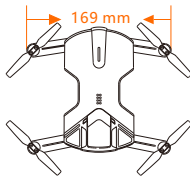
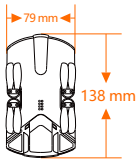
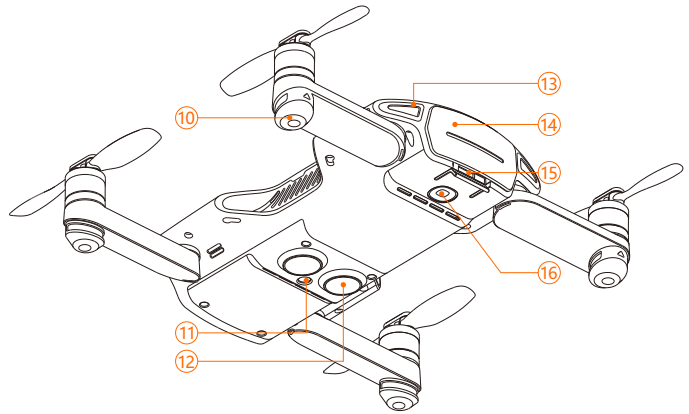

1.4 Preparing the aircraft

Propeller

Unfold 4 folding arms to maximum position. Extend 4 pairs of sot propellers into ready-to-fly form. Insert the Micro-SD card into SD card slot (max capacity support: 32G). When finish the flight, fold the propellers and arm. With the propellers blocking protection feature, the flight control system will stop all motor rotation when the propellers run into obstacles, reduce the damage caused by faulty operation.

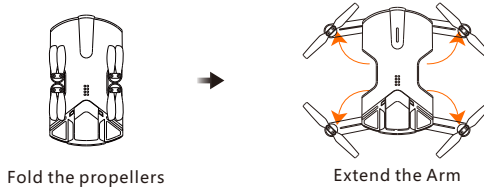

Change the propellers

Unscrew the covers on the motors, install new propellers with the same direction of rotation according to the ⊕ or ⊖ symbol. Then Screw the covers back on the motors firmly.

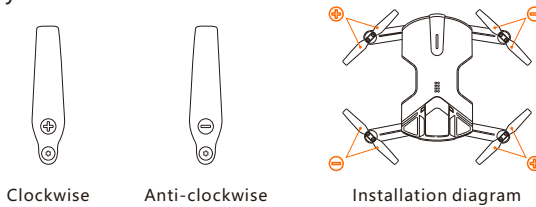

Flight Battery

Power the battery by using the S6 specialized charging base, connect to a suitable power source or a portable power bank. A red solid LED indicates the battery is charging. A green solid LED indicates the battery is fully charged. Disconnect the charger and the battery when fully charged or an alternately green and red LED flash which indicates a battery error has occurred.

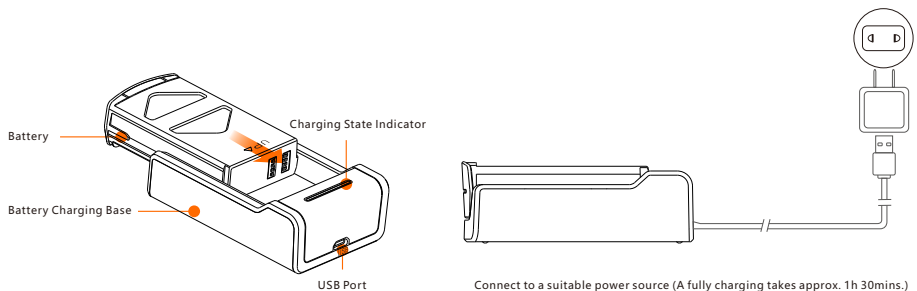

Battery Installation

Insert the battery into the compartment. The power button is located at the bottom of the aircraft.

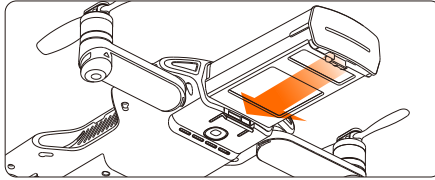

Battery Installation

Remove the Battery

Flip over the aircraft, use your thumb or a coin to lever up the compartment lock and pull out the battery.

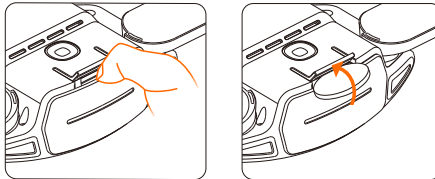

Remove the Battery

Power ON/OFF

Slide the battery of aircraft for 5 seconds to power on the aircraft. A continuously short beep sound indicates the aircraft is self-checking, a long beep sound indicates self-checking is complete and the aircraft is ready to fly. Press and hold the power button for 5 seconds to power off the aircraft.

2. Flight Control

2.1 Flight Mode

1. Standard Mode

● GPS Mode

With the help of dual satellite (GPS+GLONASS), S6 can hover steadily in an outdoor area when the number of searched-out satellites ≥ 7 . The User can check the satellite number on the mail interface of APP.

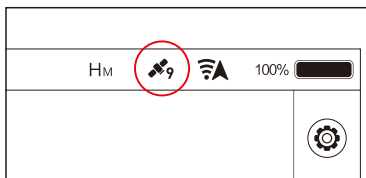

Satellite Number

⚠ When flying outdoor, a sufficient GPS reception is needed for a safe takeoff(GPS satellite number ≥ 7). Please find an open area to takeoff when a good reception is not available.

● Vision Positioning System

With the help of the Vision Positioning System, the aircraft can hover in place precisely when flying indoor or in other environments where the GPS signal is unavailable.

The system functions through a monocular camera which obtains location information by real-time image analysis, an infrared sensor which identifies the current height of the aircraft. The system is only valid when the aircraft is between 0.7m and 2.5m above the surface.

⚠ The performance of the Vision Positioning System is affected by the aircraft flying speed, brightness and texture of the surface which the aircraft is flying over.

- Flying at a high speed while at a low altitude.
 - Flying over a highly reflective surface.
 - Flying over a monochrome surface or a water surface.
 - Flying in an extremely dark or bright environment.
 - Flying over a inclined surface which is tilted over 30 degrees.
 - Flying over a moving surface or object.
 - Flying over a surface with unclear patterns or highly repeating patterns.
-

● Altitude Mode

When the GPS reception is poor, and Vision Positioning System is not in working situation, the aircraft will use barometer to only maintain its altitude (the aircraft may be drifted by inertia effect). Control the aircraft return to home if a drifting occurs.

2. Beginner Mode

Under the Beginner mode, the speed is limited to 1.5 m/s, easy for users to learn to control the drone.

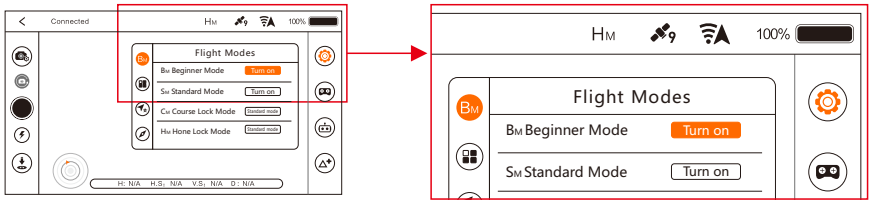

How to activate the Beginner Mode

- ① S6 can only take off on the outside environment with 7 or more satellites.
- ❗ ② Only use the Auto takeoff function to take off.
- ③ The speed is limited to 1.5 m/s.

3. Course Lock Mode

When the aircraft fly far away, the user can't distinguish the nose direction. The course lock function will enable you to quickly control the aircraft back. Activate the course lock mode, the forward direction will be relative to the nose direction when takeoff. Easily distinguish the aircraft direction.

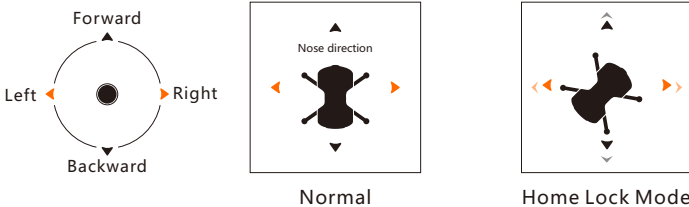

Tap onto the "course lock mode" icon and follow the prompt instruction to activate it.

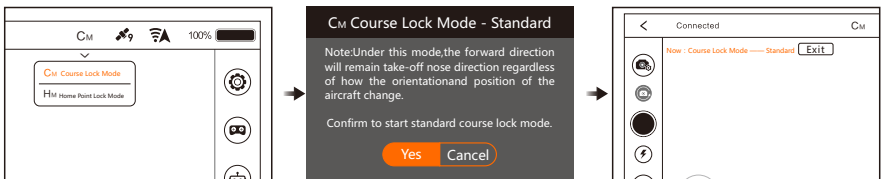

Tap onto the "course lock mode" icon

Prompt

Under course lock mode

4. Home lock mode

When fly far away from sight, the home lock function will help user to easily control aircraft back to hope point. Activate the home lock mode, fix your forward direction controls to be relative to the Take Off Point. Easily pull back on the right control stick (mode 1) to bring the aircraft back home point, or push forward to fly farther away, no matter which way it is facing. Move the right control stick to left or right direction, the aircraft will circle the home point.

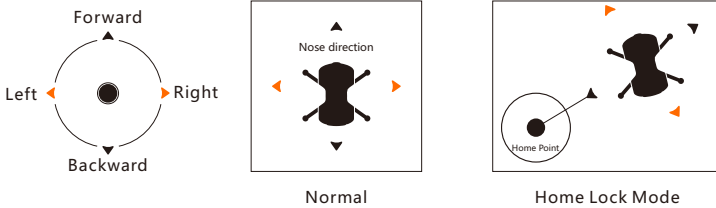

Tap onto the “home lock mode” icon, and follow the prompt instruction to activate it.

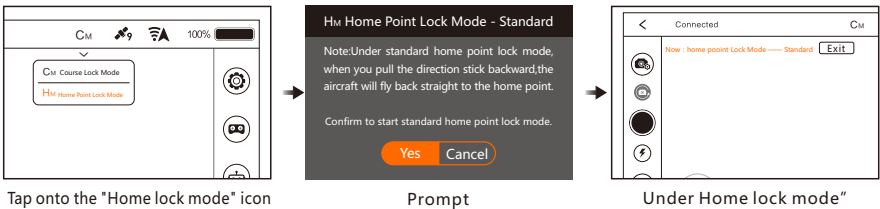

Home point: When the aircraft take off, a place where the aircraft search 7 or more satellites at the first time.

2.2 Auto Return-to-Home

Tap the Auto Return-to-Home icon (📍) in flying interface and Confirm (👉) to command the aircraft return to the last recorded home point in a preset altitude. The auto Return-to-Home function can be canceled during a Return-to-Home flight by tap the exit icon or move virtual joysticks.

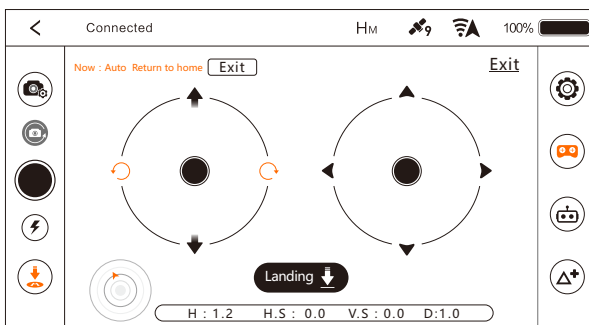

APP Interface

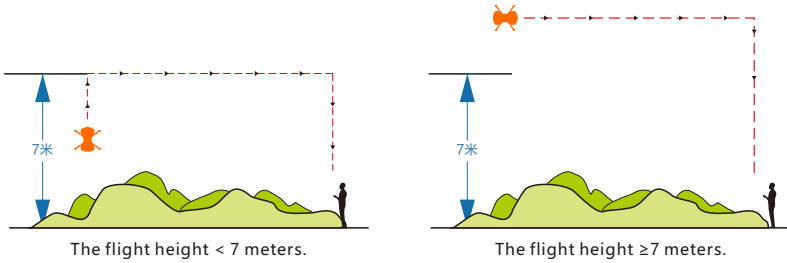

Exit Auto Return-to-Home Mode : Return-to-Home function can be canceled during a Return-to-Home flight by tap the exit icon or move virtual joysticks.

Exit Auto Return-to-Home mode, craft will enter the hovering on standby.

! When the GPS signal is not good or GPS does not work, Auto Return-to-Home will not work.

2.3 Flight Protection

Low Battery warning/Landing

A red prompt on the screen will appear when the flight battery level is 30 percent left. It means that the low battery warning is triggered. Please choose a suitable ground and control the aircraft to land soon. When the battery level is 10 percent left, the aircraft will land automatically. During the landing process, the user can still use the control stick except for the throttle stick.

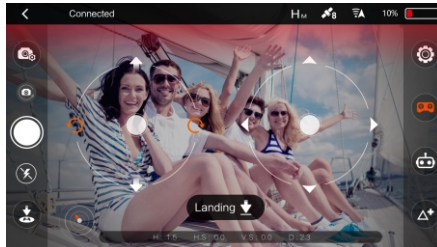

- ! ① When the aircraft start automatically after landing, Auto Return-to-Home will not work.
 ② The low voltage triggering the alarm, please be sure to return the aircraft and landing, to prevent lost power after the danger to the aircraft, human and animal.

Failsafe RTH

When the control signal between aircraft and smart device is lost, the flight control system will control the aircraft to return to home point and automatically land. The land point is the place where the aircraft search 7 or more satellites at the first time.

When the altitude is above 7 meters, the aircraft will keep the altitude and return to home point. If the altitude is below 7 meters, the aircraft will automatically ascent to 7 meters, then return to home point.

! The failsafe RTH function could not be activated if the GPS satellite is not enough.

3. WINGSLAND FLY APP

WINGSLAND FLY APP is a mobile application designed specifically for WINGSLAND S6. WINGSLAND offers an ideal and powerful mobile device remote solution for control your S6 with the virtual remote FPV monitor and flight critical information display. With inbuilt simulator software and guidelines for beginner, you will soon get the hang of it. The app allows you to edit and share your photos and videos with others through SNS platform.

3.1 Flying Interface Introduction

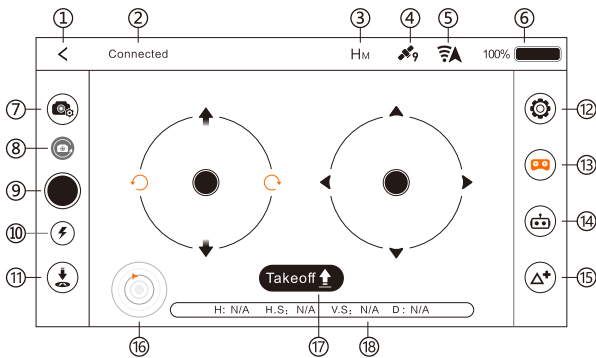

- ① Back
- ② Connection Status
- ③ Flight Mode
- ④ Satellite Signal
- ⑤ Wi-Fi Signal
- ⑥ Battery Level
- ⑦ Camera Setting
- ⑧ Camera Mode Switch
- ⑨ Shutter
- ⑩ Flash
- ⑪ Auto RTH
- ⑫ General Setting
- ⑬ Control Mode
- ⑭ Intelligent Flight Mode
- ⑮ Accessories Features
- ⑯ Radar
- ⑰ Auto Take Off/Landing
- ⑱ Flight Real-time Data

Intelligent Features

• Point of Interest

The aircraft will orbit around the subject automatically in POI mode. To perform POI, you need fly the aircraft above the object that you are interested in, and then move your aircraft from the current location to your desired location to set the orbit radius. After that the aircraft will fly in a circle with the camera fixed on the object.

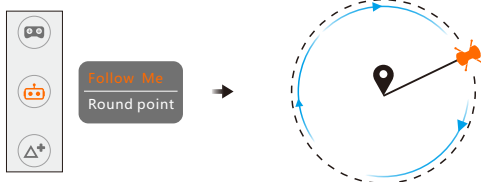

! If the radius is smaller than 5 meters, the aircraft will automatically fly away from the point to 5 meters and perform POI.

• Follow Me

After confirmed Follow Me function, the aircraft will follow the operating mobile device automatically.

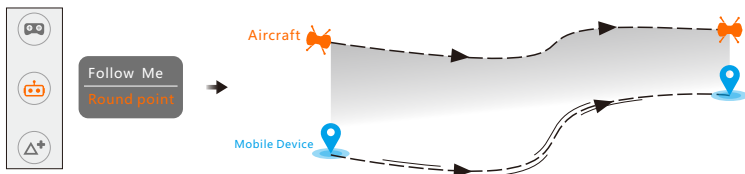

! Please enable the GPS function on your mobile device. Active the Follow Me function when the aircraft is 5 meters away for best function performance. Do not cover your mobile device, and do not shake your mobile device during the Follow Me.

Accessories

Accessories Interface

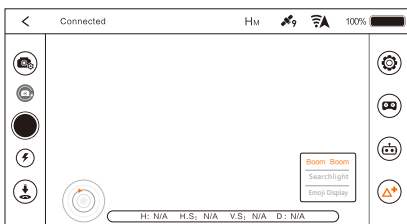

Accessories Menu

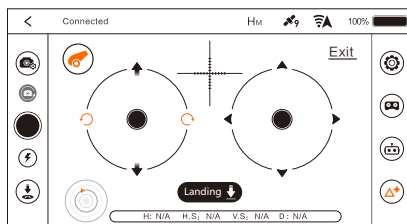

Boom Boom  shoot

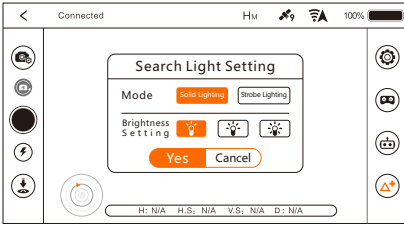

Searchlight

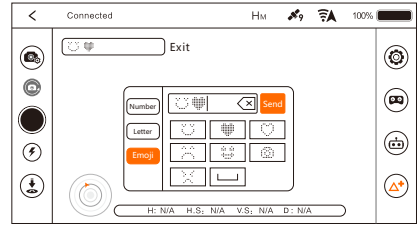

Emoji Display

• Boom Boom

Aim through the crosshair on the app FPV screen, choose the target and fire.

Boom Boom Installation

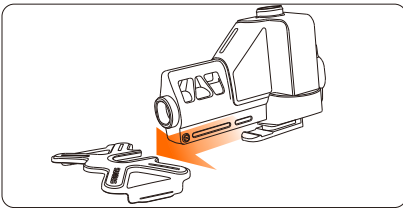

① Slide the Boom Boom into the buckle.

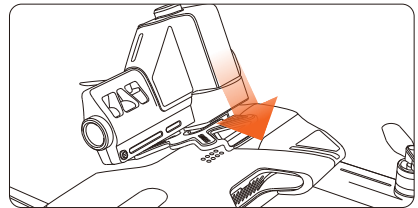

② Clasp the buckle on one side first, then push the buckle down to lock it on both side.

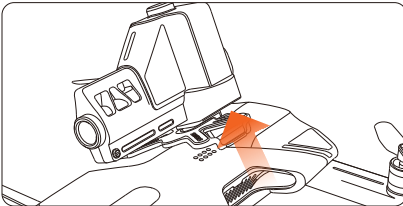

③ To remove the buckle, gently lever up one side first, then take off the buckle.

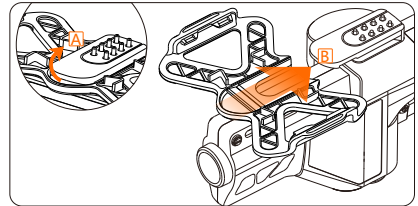

④ Lever Boom Boom's bottom up **A**, and push it out of the buckle **B**.

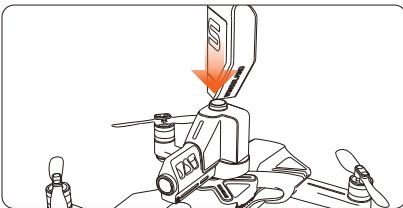

⑤ Use bullet clip to fill the Boom Boom.

⚠ Do not aim at people or animals.

● Emoji Display

The display board will show the numbers, letters or emoji which are typed through the APP.

Emoji Display Installation

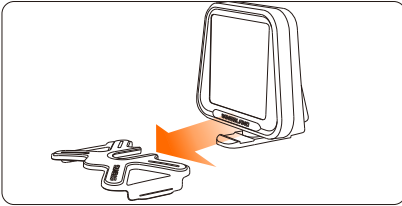

① Slide the Emoji Display into the buckle.

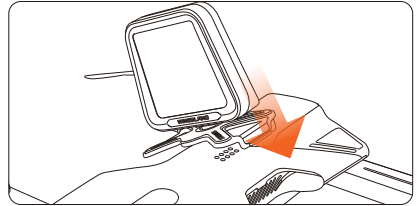

② Clasp the buckle on one side first, then push the buckle down to lock it on both side.

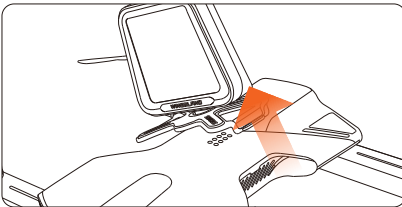

③ To remove the buckle, gently lever up one side first, then take off the buckle.

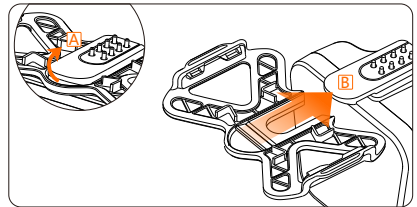

④ Lever Emoji Display' s bottom up **A**, and push it out of the buckle **B**.

● Searchlight

You can change different level of brightness and flash modes through the APP.

Searchlight Installation:

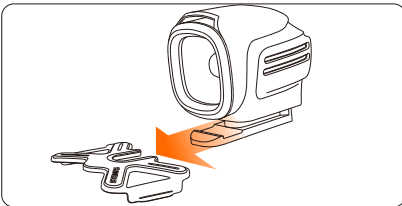

① Slide the Searchlight into the buckle.

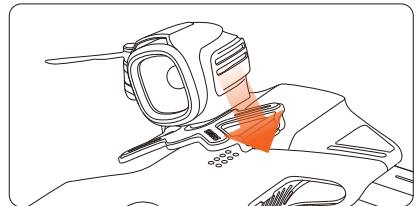

② Clasp the buckle on one side first, then push the buckle down to lock it on both side.

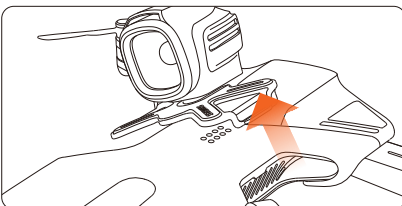

③ To remove the buckle, gently lever up one side first, then take off the buckle.

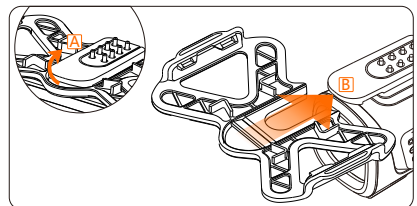

④ Lever Searchlight' s bottom up **A**, and push it out of the buckle **B**.

● Propeller Guard

For a safe flight please install the Propeller Guard.

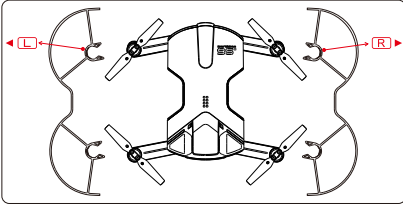

- ① **L** install on the left side of the aircraft.
R install on the right side of the aircraft.

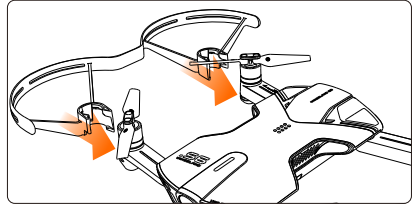

- ② Clasp the Prop Guard on the arms of the aircraft firmly.

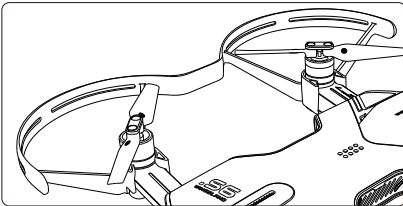

- ③ Same way to install both of the Prop Guard.

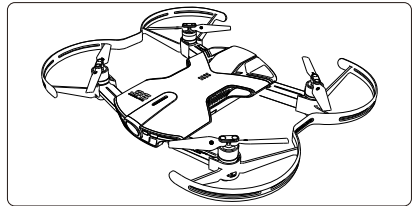

- ④ Make sure the Prop Guard is installed firmly before takeoff.

3.2 Simulator

Train your flying skills in the simulator and be skillful at a real flight. The simulator brings all the features and controls just like the real flying experiences.



3.3 Editing

The video editor which built in the WINGSLAND FLY can let you cut and render your video, add back ground music, subtitles and share with your friends.

Learn more about the editing:

<http://www.szungreen.com/instance.php?CatelId=14>

4. Flight

4.1 Flight Safety Notice

- Only fly in an open area and always fly your aircraft within line of sight.
- Always fly at locations that are clear of buildings, crowds, trees, power lines, and locations where may have a chance of strong magnetic interference.
- Do not fly the aircraft within areas such as airport, no-fly zone. Observe local laws and regulations. Keep the aircraft flight range and height within 100 meters.
- Do not use the aircraft in severe weather conditions: snow, rain, smog, windspeeds exceeding 5m/s, etc.
- Be very careful when flying at 6000 meters or more above sea level. The aircraft Functions may be affected by the environmental conditions.

4.2 Preflight Checklist

- Mobile device and flight battery are fully charged before flight.
- Make sure that the Wingsland Fly application and flight control firmware are the latest version.
- Unfold the 4 folding arms to maximum position. Propellers are mounted correctly and firmly.
- Micro-SD card has been inserted. The maximum capacity is 32G.

4.3 Flight Control





Calibration

Make sure to calibrate the compass every time when flying in a new location. The compass is very sensitive to electromagnetic interference that may cause abnormal compass data and lead to flight failure. Regular calibration is required for optimal performance.

When to calibrate:

- Flying in a new location or in a location that is different from the last flight.
- A drift occurs when the aircraft is hovering.

Calibration procedures:

Tap into the general setting menu  and select the compass calibration icon . Place the aircraft on a flat ground  and confirm to start the calibration. When indicators of the aircraft flash slowly, rotate the aircraft 360 degree clockwise in same altitude for at least 6 times . The indicators should all be solid and the APP displays calibration successful if the compass has been successfully calibrated.

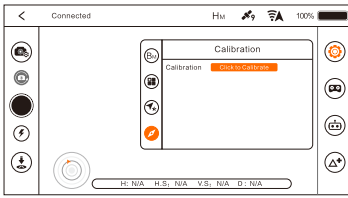

①



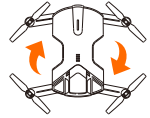

②





③



- Do not calibrate in strong magnetic field.
- ! • If the repeated calibration is not successful, please transfer to other places for calibration.
- Do not be in the vicinity of high-rise buildings or metal surface calibration.

Auto Takeoff/Landing

In the flying interface, tap the Auto Takeoff icon , then tap  to active the feature. The aircraft will automatically hover up 2.5m above ground and stabilize.

After takeoff, the Auto Takeoff icon will change to Auto Landing icon , Tap the icon  the aircraft will automatically perform the landing. Check the landing area condition and make sure no obstacle in landing way before the landing.

Return-to-Home

Tap the Auto Return-to-Home icon  in flying interface and Confirm  to command the aircraft return to the last recorded home point in a preset altitude. The auto Return-to-Home function can be canceled during a Return-to-Home flight by tap the exit icon or move virtual joysticks.

! If the aircraft is flying under 7 meters, the aircraft will automatically ascend to 7 meters from the current height. If the current height is 7 meters or above 7 meters, the aircraft will return to home point with the current height.

Control Mode

• Virtual Joystick Mode

In the flying interface, tap  two virtual joysticks will be displayed on the APP screen to correspond the operation of the remote control sticks. The virtual joysticks are set to Mode2 by default (Mode1 and Mode2 can be switched under general setting). The left joystick controls the throttle and rotation of the aircraft, the right joystick controls forward, backward, left, right movement of the aircraft.

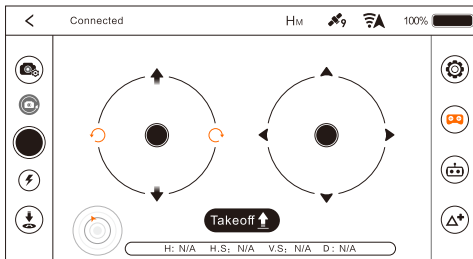

Virtual Joystick Mode

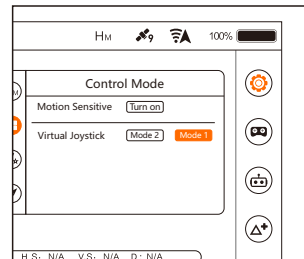

Switch Mode 1

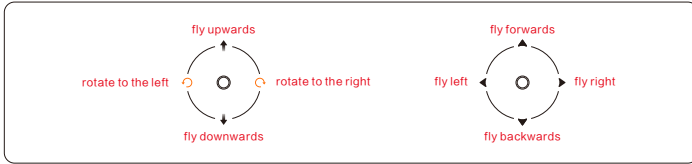

Mode 2

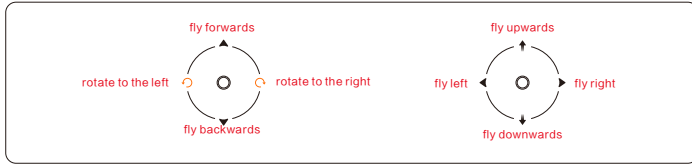

Mode 1

• Motion Sensitive Mode

Change the motion-sensitive mode by tapping the Motion sensitive icon. A joystick will be displayed on left of the APP screen, which controls the throttle and rotation of the aircraft. Tap and hold the orange round on the right of the APP screen. The APP will record current inclined position of mobile device as a referenced position. Then tilt the mobile device to control the motion of aircraft when the round turns green. Tilt the mobile device up/down, the aircraft will fly forward/backward. Tilt the mobile device left/right, the aircraft will fly toward left/right.

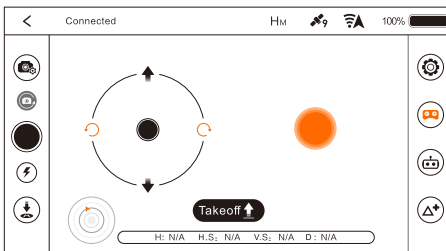

Motion-sensitive Mode Interface

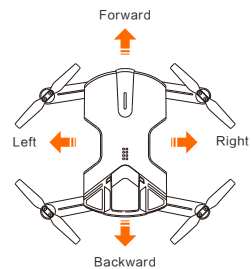

Nose Direction of Aircraft

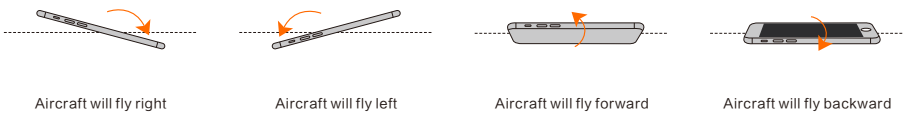

! Motion Sensitive Mode only works under the Mode2. (Model - The right joystick serves as the throttle. Mode2 - The left joystick serves as the throttle. For more information, please refer to the S6 User Manual)

Appendix

S6 Specifications

Aircraft	
Weight	250g (include battery)
Dimensions	Ready to Fly form : 138*169*32.6 (mm)
	Folded up form : 138*79*32.6 (mm)
Max Service Ceiling Above Sea Level	100m
Max Transmission Distance	100m
Max Flight Time	Approx. 10 Minutes
Operating Temperature	0-40°C
Max Wind Capability	Category 3
Positioning System	Outdoor: GPS
	Indoor: Ultrasonic and Optical Flow Sensor
Hover Accuracy	Vertical: +/- 0.1m(Ultrasonic sensor active); +/- 0.5m(GPS mode)
	Horizontal: +/- 0.3m(Optical flow sensor active); +/- 0.1(GPS mode)
APP	
APP Name	WINGSLAND FLY
Live View Quality	480p,720p
Latency	200ms (depends on environments and mobile devices)
OS Requirement	iOS 9.0 (or later), Android 5.0.1 (or later)
Battery	
Capacity	1400mAh
Battery Voltage	7.6v
Energy	10.64Wh
Battery Type	Lithium-ion Polymer Battery
Net Weight	74g
Charging Environment Range	0-40°C
Discharging Environment Range	0-40°C

Camera	
Sensor	Effective Pixels: 13M
Lens	F/2.2, Focus at Infinity
Exposure Compensation	+4,+3,+2,+1,0,-1,-2,-3,-4
Photo Resolution	12MP 4032x3024 4:3
	8MP 3264x2448 4:3
	5MP 2592x1944 4:3
Video Resolution	1920x1080 60P 16:9
	3840x2160 30P 16:9
	2560x1440 30P 16:9
	1920x1080 30P 16:9
	1280x720 120P 16:9
	1280x720 60P 16:9
Anti-Flicker	Auto, 50Hz, 60Hz
Still Photography Modes	Single Shot Mode, Burst Mode, Timer Photo Mode
Slow Motion Video	Normal, 1x, 2x, 3x
Timer Photo Mode	Turnoff, 5s Delay, 10s Delay
Video Standard	PAL, NTSC
File Format	MP4 JPEG
USB Type	Micro-USB
Wi-Fi	
Wi-Fi Name	WINGSLANDs6_air_XXXXXX
Wi-Fi Frequency	2.4GHz; 5.8GHz
Transmitter Power	FCC:23dBm CE:19dBm
Charger	
Charging Port	Micro USB (supports portable power bank)
Input	5V/1A-2A (self-adapted)
Output	8.7V/0.5A-1A (self-adapted)

Certificates

FCC, CE, SRRC, KCC (MSIP) , NCC ,WEEE, RoHS

