

Specification:

-BB21 MCU, 48Mhz Runs BLHELI_S_J_H_xx firmware
-Supports 2-6S Lipo input
-4PWM input
-Continuous current: 35A
-Peak Current: 40A (10S)
-Built-in Current sensor
-Only 36x36mm, mount holes 30.5x30.5mm M3
-No External capacitors needed
-No BEC output
-Dshot600 ready(Default) Support PWM/ONESHOT/MULTISHOT/DSHOT

Pin out Diagram:

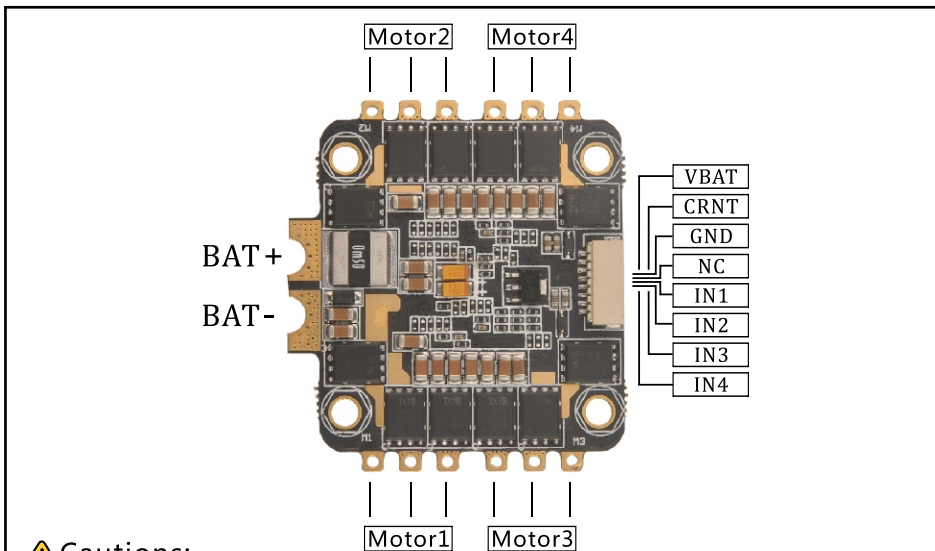

⚠ Cautions:

The IN1 match motor1 ,IN2 match motor2 ,IN3 match motor3 , IN4 match motor4 They are not definitions to the motor number of the quadcopter in CLEANFLIGHT or BETAFLIGHT CONFIGURATOR , Please adjust the ESC signal wires according to the Mixer map  
CRNT is Current sensor ,Vbat is battery direct output(no bec)

Software and Betaflight pass-through:

- 1.Download New release Blhelisuite
- 2.Connect the Rev35A 4in1 ESC to flight controller runs Betaflight or Cleanflight
- 3.Connect the flight controller to computer and power for the Rev35A 4in1 ESC
- 4.Open the Device Manager of your computer ,find the Ports, please make sure the Com port Serial Number is under 255, otherwise it will can' t connect to the BLHELISUITE. You can change the port serial number like the step :

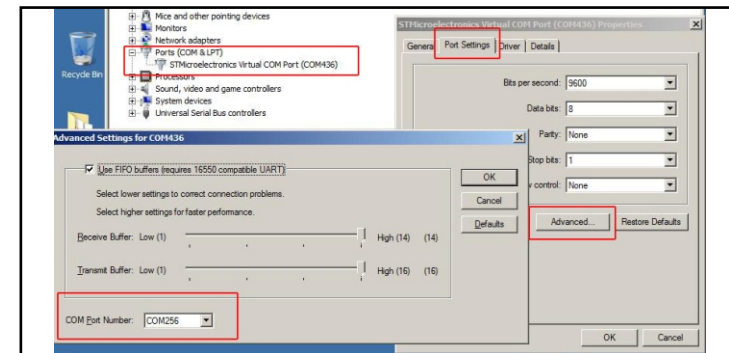

- 5.Open the BLHELISUITE, Select SILABS BLHeli Bootloader (Cleanflight) from the third tab on the top side. Then Select the right Serial com port and Click connect. You can also Flash the new release BLHeli\_s firmware via the BLHELISUITE, Target J-H-XX.

