

# Fokker Dr.I Balsa Wood Airplane

## Instruction Manual

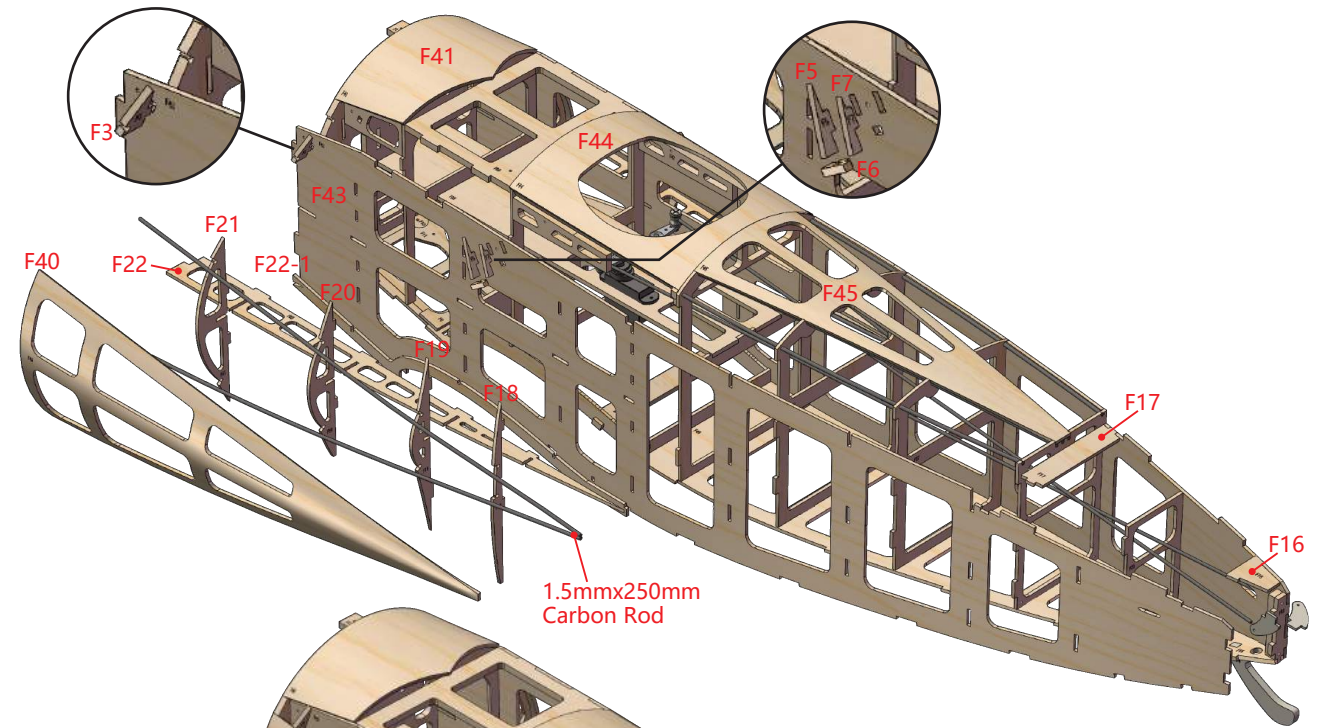
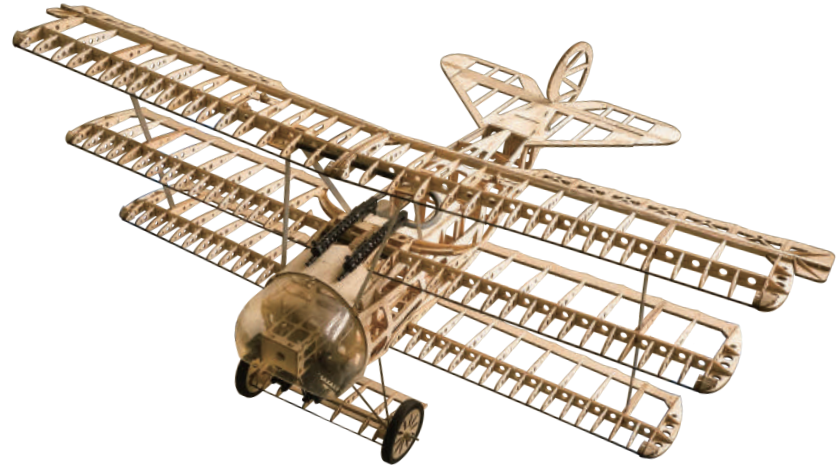

### 1. Assemble the Fuselage

### 2. Assemble the wing of landing gear

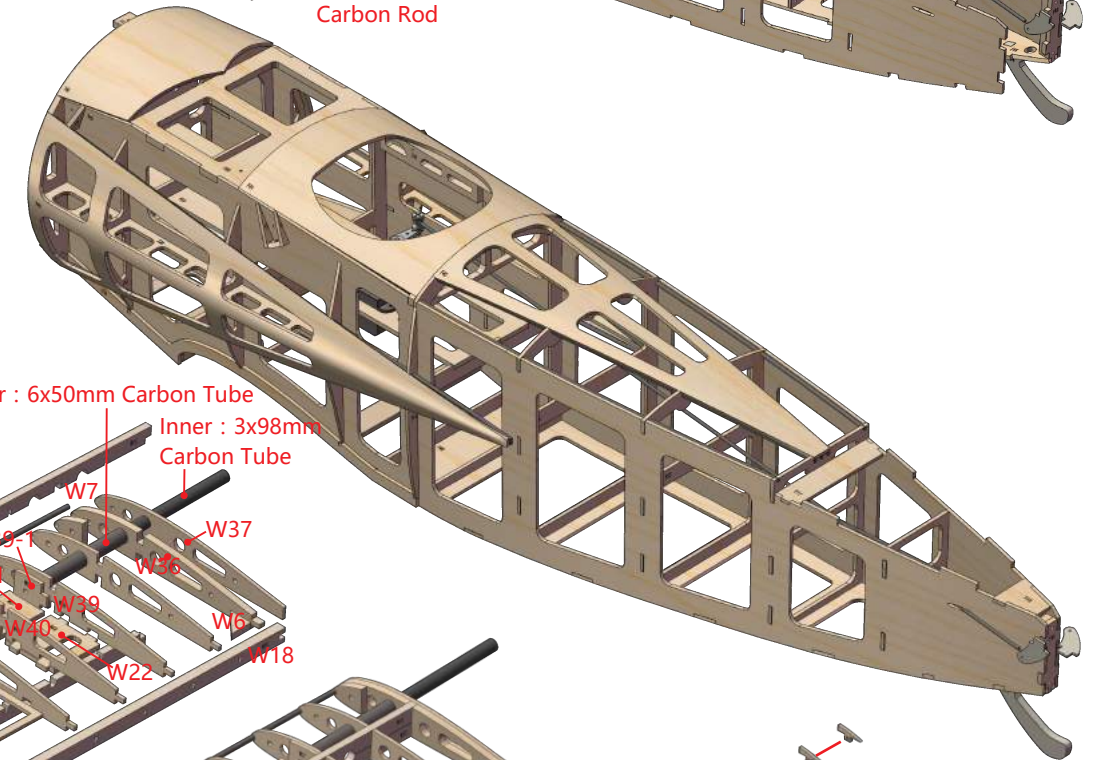
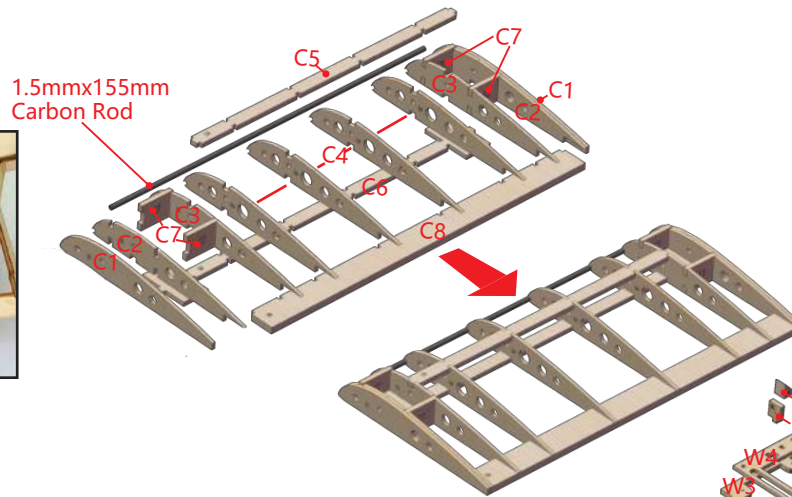
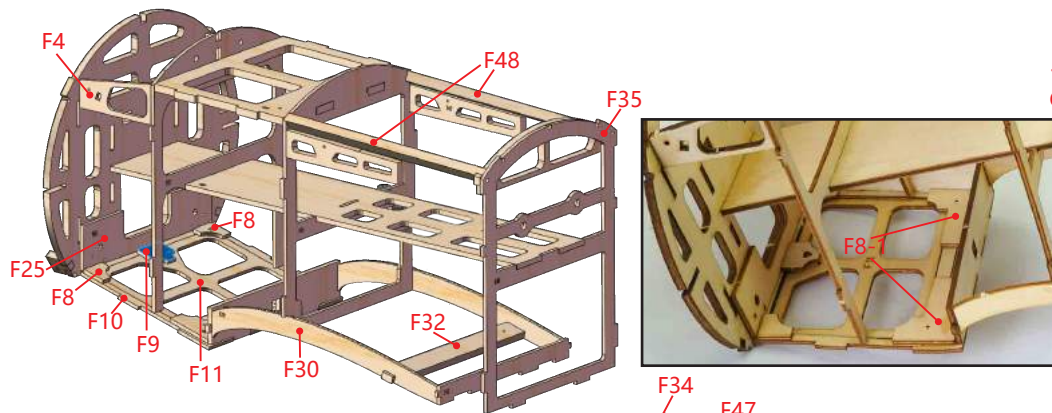

### 3. Assemble the upper wing

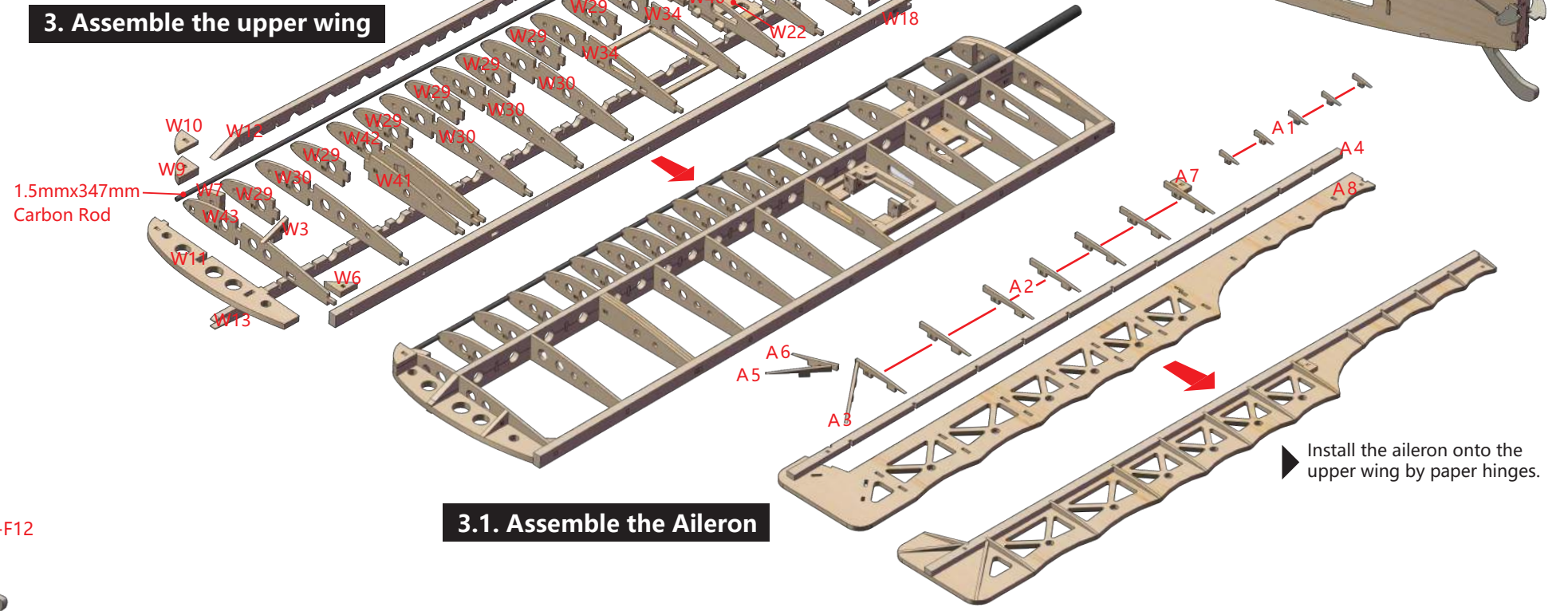
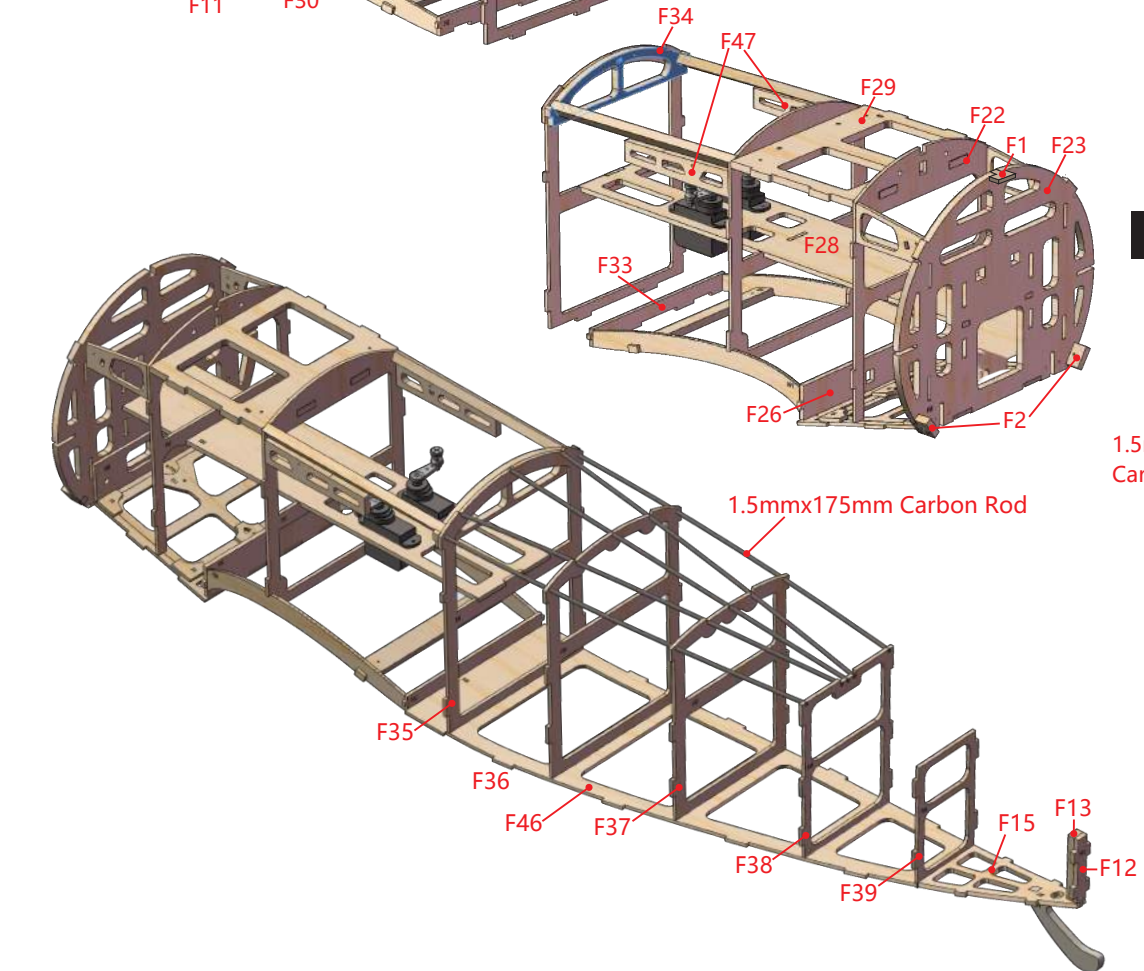

### 3.1. Assemble the Aileron

Install the aileron onto the upper wing by paper hinges.



#### 4. Assemble the middle wing

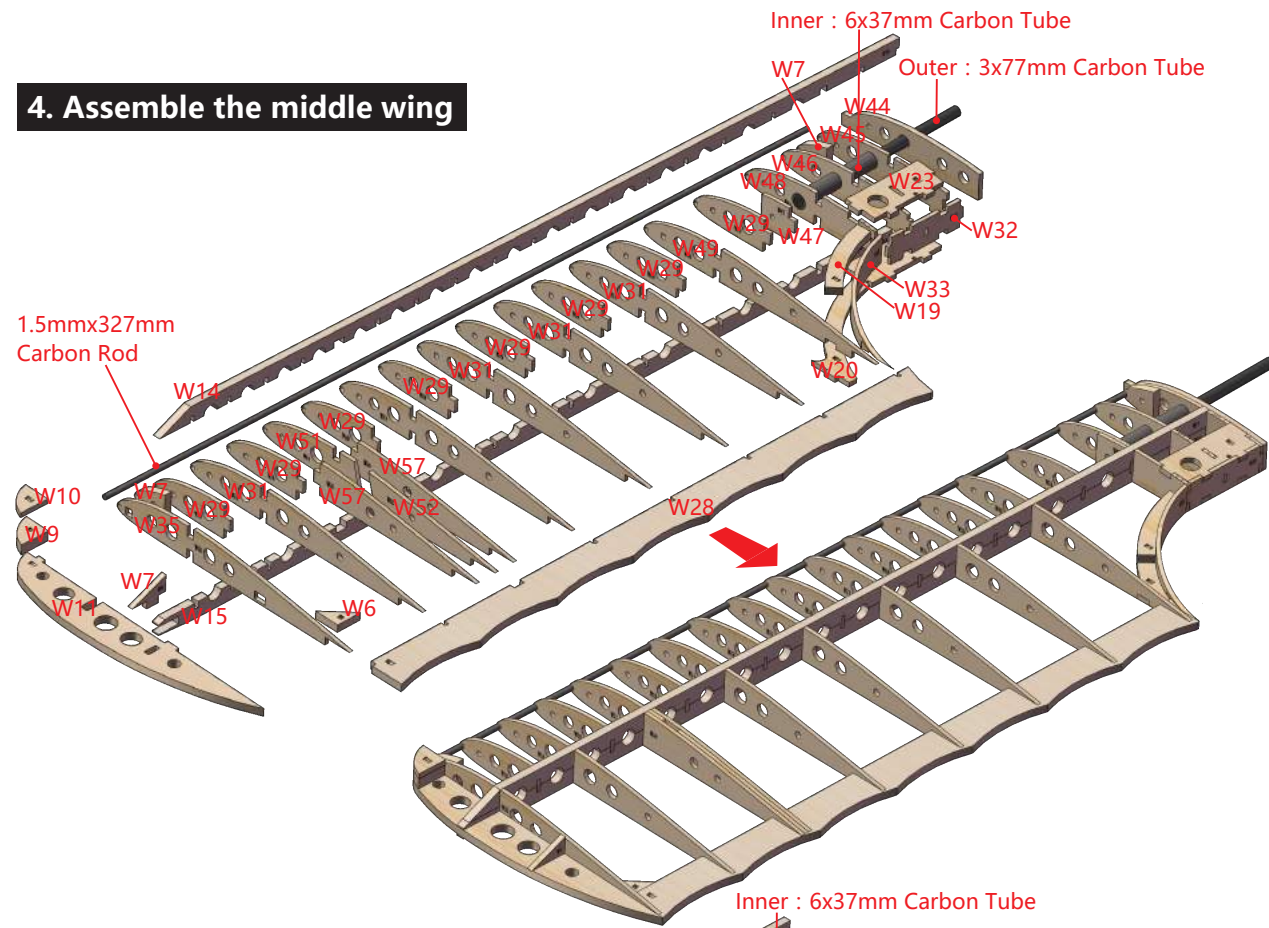

#### 5. Assemble the lower wing

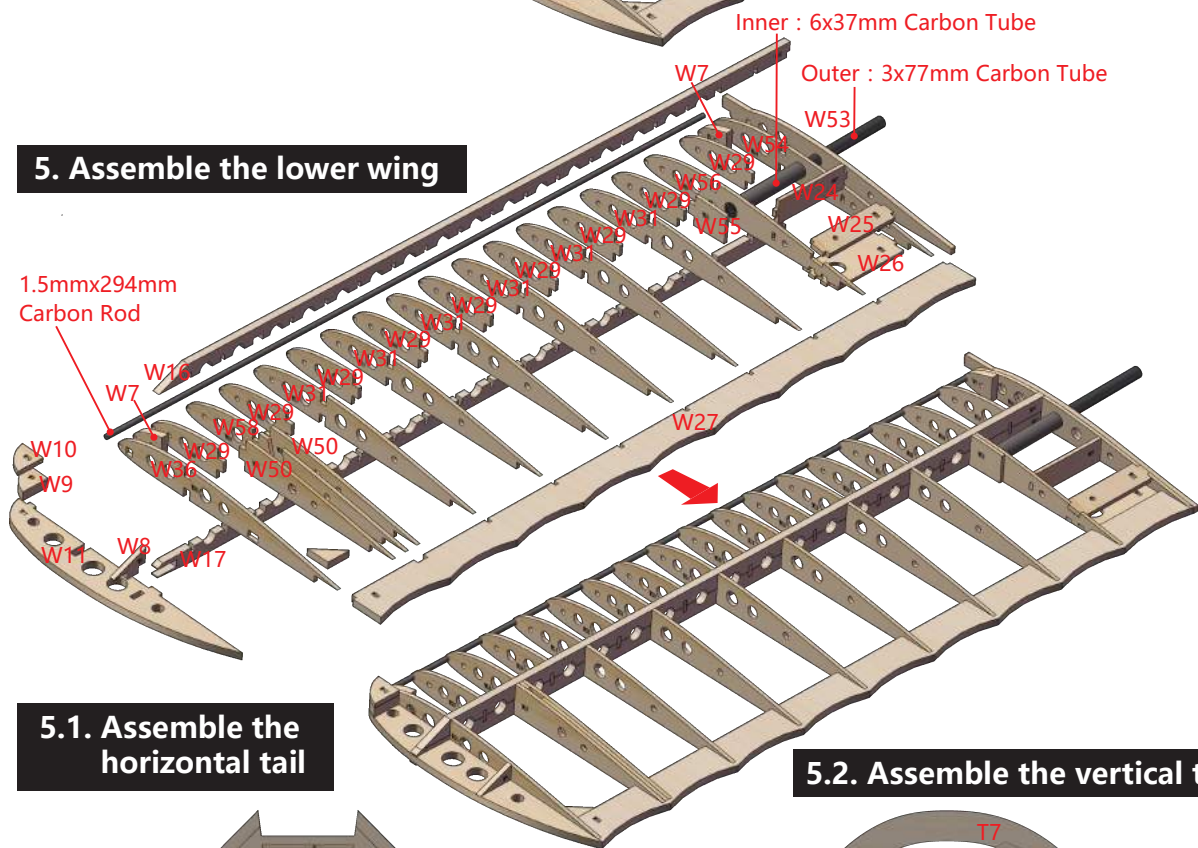

#### 5.1. Assemble the horizontal tail

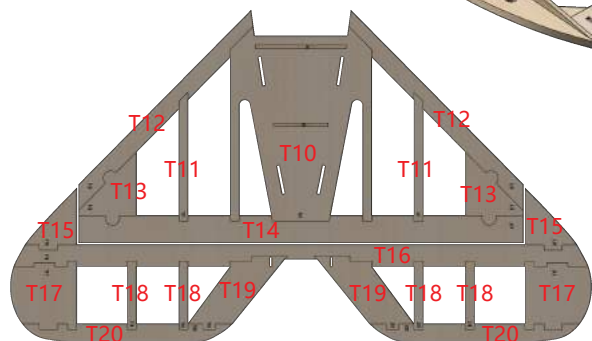

#### 5.2. Assemble the vertical tail

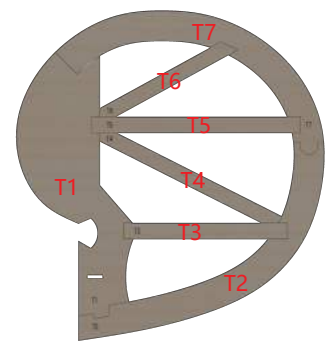

#### 6. Assemble the other components

6.1 Install the horizontal and vertical tail onto the fuselage.

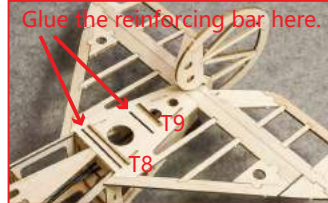

Fix the horizontal tail with glue.

6.2. Assemble the wing

6.2.1. Plug and assemble together the middle wing, then install onto the fuselage.

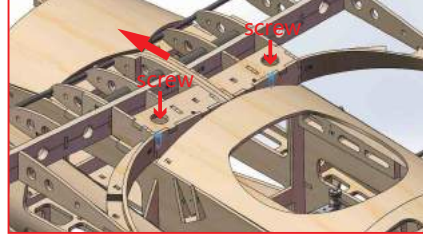

6.2.2. Plug and assemble together the upper wing, then install onto the fuselage by aluminum rod and fix with screws.

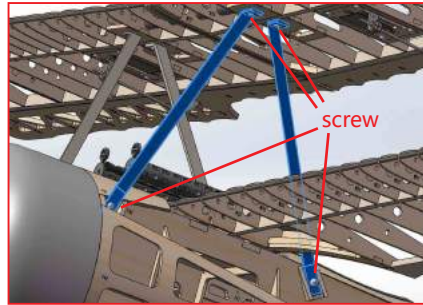

6.2.3. Plug and assemble together the lower wing, then install onto the fuselage.

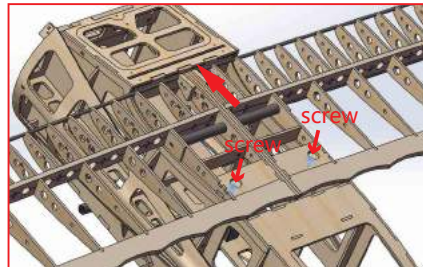

6.2.4. Connect the upper, middle and lower wing by aluminum rod (as ▲ marked)

Assemble the vertical tail onto the fuselage by paper hinges.

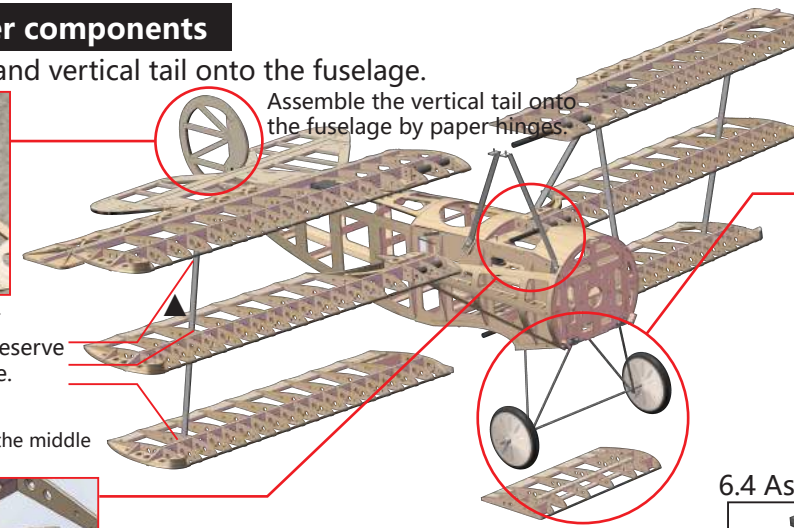

6.3 Install the landing gear and wing of landing gear.

6.3.1 Install the landing gear onto the fuselage.

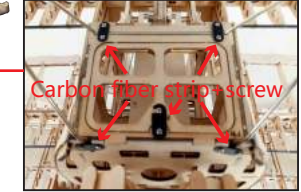

6.3.2 Assemble the wing of landing gear.

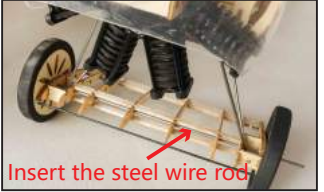

6.3.3 Assemble and install the wheel.



6.4 Assemble the cowling and scale parts.

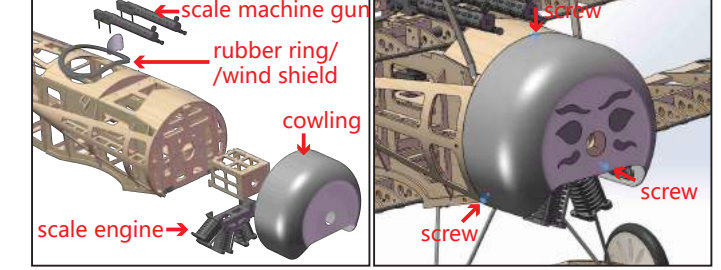

#### 7. Assemble the power system

**Specification**  
Wingspan : 770mm  
Length : 630mm  
Net weight : ≈650g

**Suggested Equipment**  
Motor : 2212 800-1000KV  
ESC : 20A  
Servo : 2.5g \*2 & 5g \*2  
Propeller : 7-8 inch  
Battery : 2-3S 1300-1800mAh  
Radio ≥ 3CH

7.1 Assemble the motor and motor mounting base.

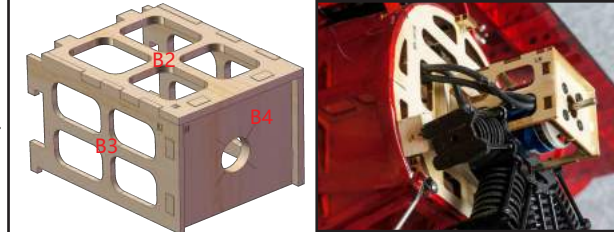

7.2 Assemble the servo and push rod for aileron.

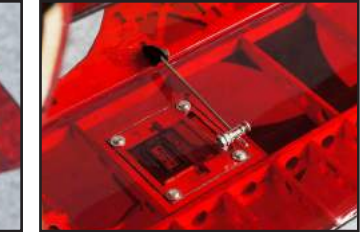

7.3 Assemble the elevator and rudder.



7.4 Assemble the servo horn and push rod for elevator and rudder.



Diagram for push rod inside the fuselage

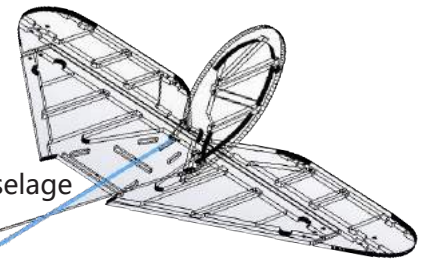

8. Adjust the C.G

