



感谢您使用本产品！本产品功率强大，错误的使用可能导致人身伤害和设备损坏，强烈建议您在设备使用前仔细阅读本说明书并保存，严格遵守规定的操作程序。我们不承担因使用本产品或擅自对产品进行改造所引起的任何责任，包括但不限于对附带损失或间接损失的赔偿责任。我们有权在不通知的情况下变更产品的设计、外观、性能及使用要求。

01 主要特性/参数

电调

- EFM8BB21F16G MCU；
- 4A 1S；
- 超小，超轻；
- 安装孔16x16mm，M2；
- BLHeli-S 固件，多种参数可设置；
- Damped light；
- 支持Dshot 150，Dshot300，Oneshot125和Multishot；
- Dshot为数字信号，抗干扰能力强，而且电调不需要校准油门行程。

F3飞控:

- CPU: STM32F303；
- 陀螺仪：MPU-6000 SPI；
- 内置2.4G接收机
- 通道: 8CH；
- SBUS 输出；
- 遥控范围：80M（空旷环境）；
- 适用于使用OpenTX开源固件的部分遥控器。

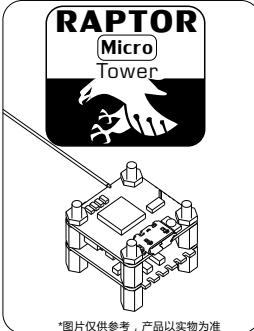

02 产品规格

型号	持续电流	瞬时电流(10S)	BEC	锂电池节数	重量(供参考)	尺寸(供参考)	典型应用(供参考)
Raptor Micro Tower	4A	5A	No	1S	5.5g	22.5x20x16.5mm	80-90mm 多旋翼

*Raptor Micro Tower 电调使用的BLHeli-S固件为 O-H-30；F3飞控使用的固件是Betaflight-TINYFISH；请联系Flycolor以获取更多信息。

03 元件清单\安装尺寸

序号	描述	数量
①	Micro Tower四合一电调	1
②	Micro Tower F3飞控	1
③	尼龙支撑柱 M2*6+5	8
④	尼龙螺母 M2	4
⑤	尼龙螺钉 M2*8	4

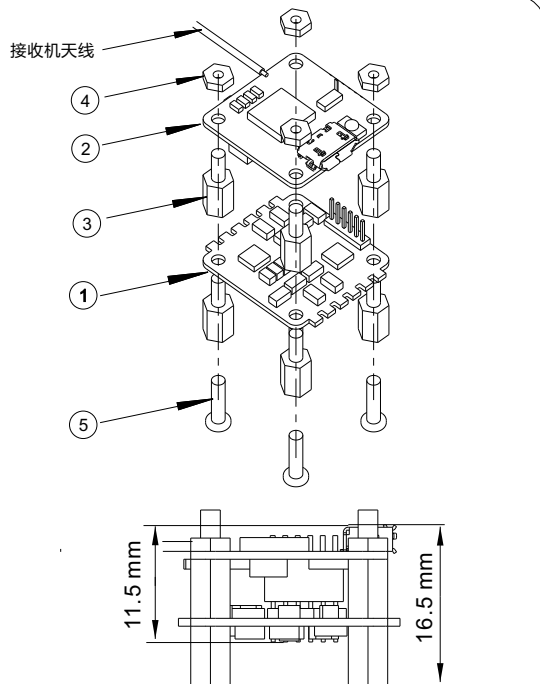
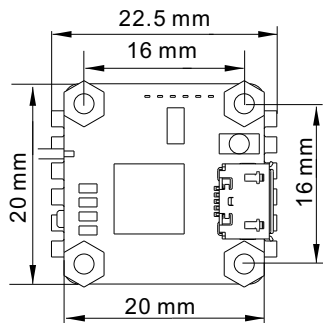

*可以通过更换底部的支撑柱，来获得合适的Tower的高度。

*图片仅供参考，产品以实物为准

03 电调及飞控连线示意图

电调

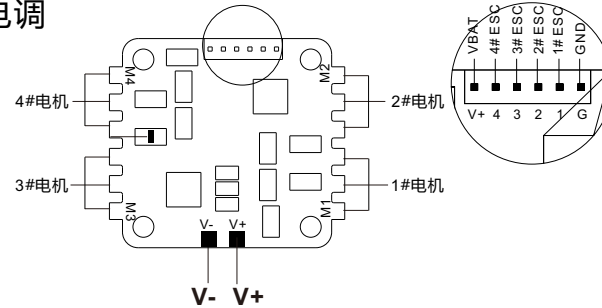

- 摄像头或其它的外部设备供电，可以连接 ESC/飞控上的 VBAT 和 GND
- 所有焊接要求良好的焊接技术，任何时候都需要避免因焊接而造成元件或线材之间短路；
- 为避免短路和漏电，请确保连接处绝缘良好；
- 接电之前务必再次检查极性是否正确；

飞控

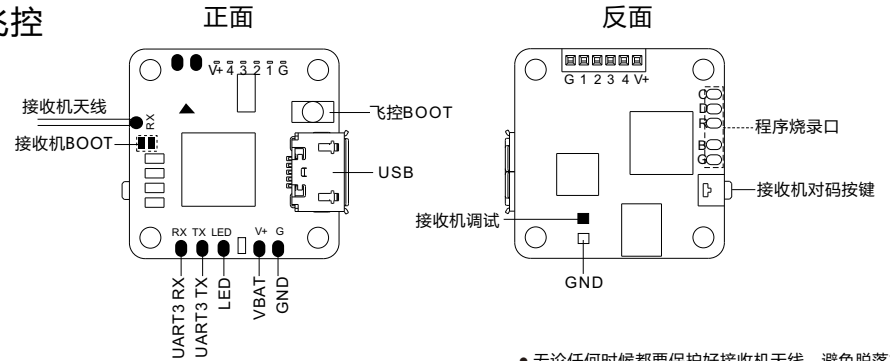

- 无论任何时候都要保护好接收机天线，避免脱落或损坏

04 遥控器和接收机对码

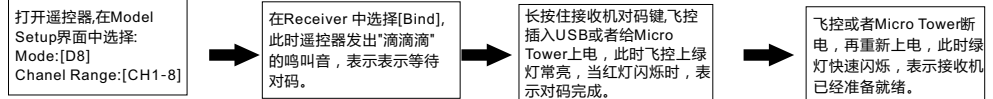

*适用于使用OpenTX开源固件的部分遥控器，请联系Flycolor以获取更多信息。

05 其它注意事项

- 首次使用无刷电调或更换遥控设备后需要进行油门行程校准；Dshot 模式时，将不再需要校准油门；
- 使用BLHeli-S开源程序，当电机出现异常或者要求达到更高转速时，可尝试更改进角参数；
- 在更换设备后需要重新与接收机对码；
- 无论任何时候都要注意极性，供电之前一定要反复检查；
- 在插拔或者做任何连接时，请关闭电源；
- 可以做一些减震措施尽量避免震动，因加速度计/陀螺仪对震动很敏感；
- 飞控要远离一切磁性材料。



Thank you for using our product. Any Improper operation may cause personal injury damage to the product and related equipments. This high power system for RC model can be dangerous ,we strongly recommend reading the user manual carefully and completely. We will not assume any responsibility for any losses caused by unauthorized modifications to our product. We have the right to change the design, appearance, performance and usage requirements of the product without notice.

01 Main features

ESC

- EFM8BB21F16G MCU ;
- 4A 1S ;
- Extra small, ultra light ;
- Mounting Hole: 16x16mm , M2 ;
- BLHeli-S firmware ; Multiple parameters can be set
- Damped light ;
- Support Dshot150, Dshot300, Oneshot125 and Multishot ; Dshot is digital signal, anti-interference ability is stronger, and do not need throttle calibration.

F3 Flight control:

- CPU: STM32F303 ;
- Gyro : MPU-6000 SPI ;
- Built-in 2.4G Receiver;
- Channel: 8CH ;
- SBUS Output ;
- Control Range : 80M (Open environment) ;
- Compatible with remote control (Transmitter) which using OpenTX firmware.

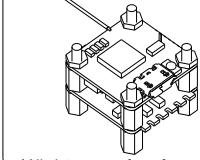

*All pictures are for reference only

02 Specification

Model	Con. Current	Burst Current (10S)	BEC	LiPo cells	Weight (For reference)	Size (For reference)	Typical Applications (For reference)
Raptor Micro Tower	4A	5A	No	1S	5.5g	22.5x20x16.5mm	80-90mm Multi

*Raptor Micro Tower is using O-H-30 BLHeli-S firmware ; F3 Flight control is using Betaflight-TINYFISH firmware ; Please contact Flycolor for more information.

03 Part list / Dimensions

Item	Description	Qty.
①	Micro Tower 4in1 ESC	1
②	Micro Tower F3 F.C	1
③	Nylon spacer M2*6+5	8
④	Nylon Nut M2	4
⑤	Nylon screw M2*8	4

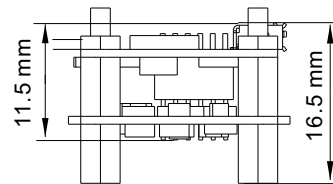
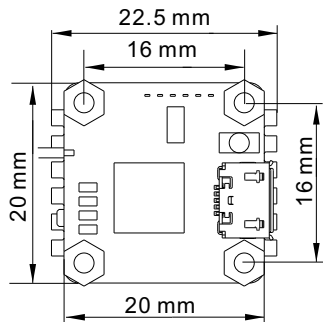
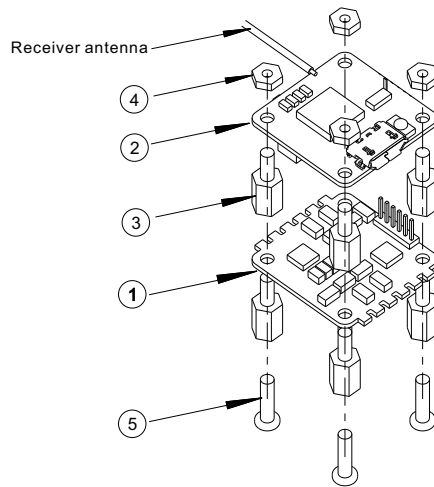

*All pictures are for reference only

*The appropriate height of the Tower can be obtained by replacing the nylon spacer at the bottom

04 Connection diagram

ESC

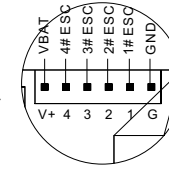
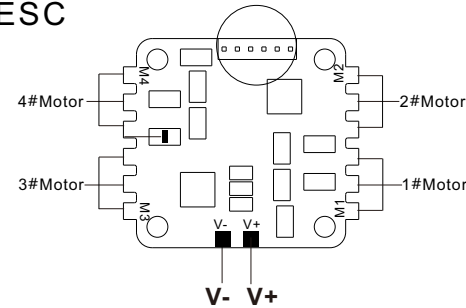

- Connect the VBAT&GND on the ESC or Flight Control to supply powered for cameras or other external devices.
- All welding requires good welding technology, short circuit between the element or the wire should be avoided at any time.
- Please ensure all solder joints are insulated with heat shrink where necessary.
- Please double-check the polarity is correct before power up.

F.C

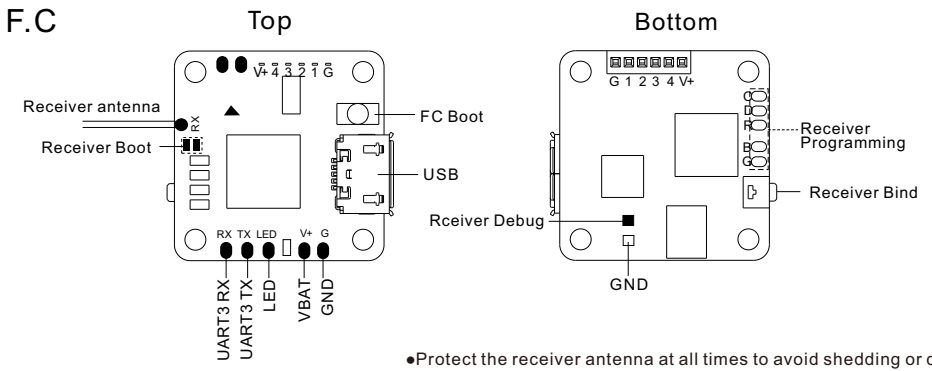

•Protect the receiver antenna at all times to avoid shedding or damage.

05 Remote control & Receiver Binding

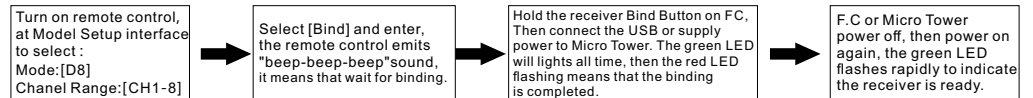

*Compatible with Remote Control(Transmitter) which using OpenTX firmware, please contact Flycolor for more information.

06 Other Attention

- User need to calibrate the throttle range when starting to use a new ESC or another transmitter. When the input signal is Dshot, throttle calibration is disabled.
- BLHeli-S open-source firmware, when some abnormality occurs in ESC driving the motor or need the motor to reach a higher RPM, user can try to change the timing.
- Re-binding the receiver and remote control (Transmitter) after changing device.
- Observe polarity at all times. Check and double check before applying power.
- Power off before unplugging ,plugging in or making any connections.
- Keep magnets away from the Flight Controller.
- Do everything you can to prevent vibrations.